



LS08-30 球式梭閥 Load Shuttle Valve, Ball-Type

描述 DESCRIPTION

螺紋插裝式液壓梭閥，用于優先接通高壓油路的截止油路。

A load-shuttling, screw-in, cartridge-style hydraulic check valve, for use in blocking circuits where a priority of flow/direction is given to a higher pressure circuit over a lower one.

工作原理 OPERATION

LS08-30 允許油液從較高壓力油口 ① 或 ③ 流向油口 ②。該閥通常用來指引油液從雙向液壓馬達的高壓端流到壓力釋放液壓制動器。

The LS08-30 will allow flow from the higher pressure of ① or ③ port to the ② port. The valve is commonly used to direct oil from the pressure side of a bidirectional hydraulic motor to a pressure-released hydraulic brake.

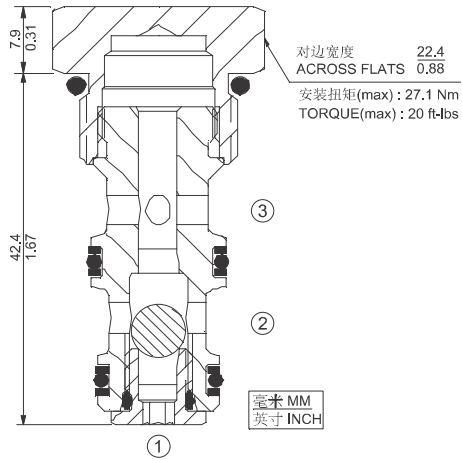

特性 SPECIFICATIONS

符號 SYMBOL	
工作壓力 PRESSURE	240 bar 3500 psi
流量 FLOW	56 L/min 15 gpm
內漏 LEAKAGE	≤ 0.25 ml/min (5 drops/min) at 207 bar (3000 psi)
密封材料/溫度範圍 SEAL MATERIAL/ TEMPERATURE	丁腈橡膠 -30°C ~ +100°C BUNA-N -20°F ~ +210°F 氟橡膠 -20°C ~ +150°C VITON -4°F ~ +330°F
過濾 FILTRATION	≤ 25 MICRONS
介質 FLUID	礦物油或具有潤滑作用的合成油 MINERAL OIL OR SYNTHETIC FLUID WITH LUBRICANT PROPERTIES
粘度 VISCOSITY	10.8~420 cSt 50~2000 ssu
閥孔 CAVITY	VC08-3

性能 (只針對插件) TYPICAL PERFORMANCE (Cartridge only)

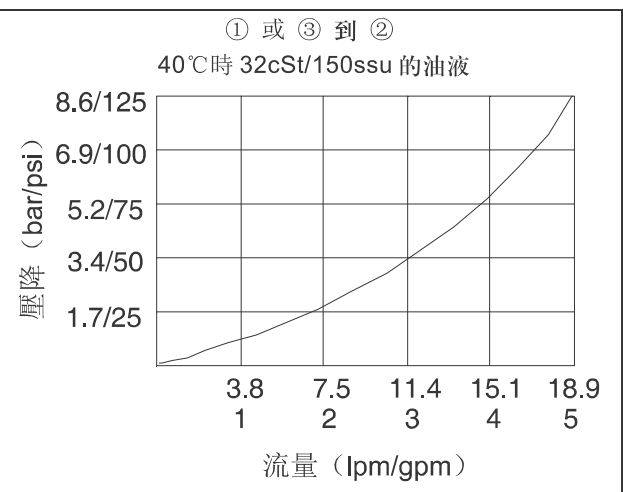

訂貨型號 HOW TO ORDER

LS08 - 30 - 0 -

密封材料
Seal Material
N: 丁腈橡膠 Buna-N
V: 氟橡膠 Viton

A

B

C

D

E

F

G

H

I

J

K

L

M

N

O

P

球式梭閥

Q

R

S

T

U

V

W