

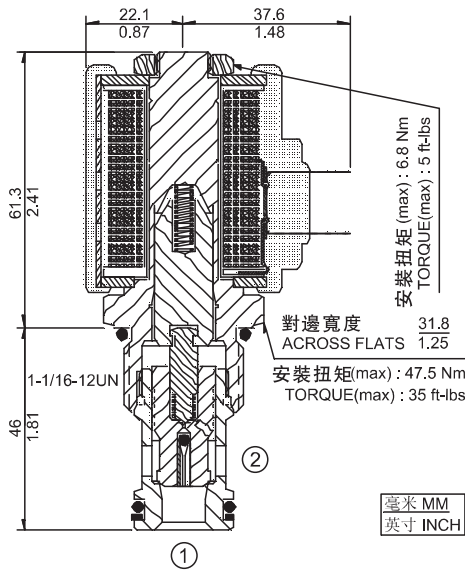

SV12-22 兩通常閉式錐閥

SV12-22 兩通常閉式錐閥 2-Way, Normally Closed, Poppet



描述 DESCRIPTION

電磁驅動、2 通常閉、座閥式、液壓螺紋插裝閥，用作低泄漏截止和負載保持應用。

A solenoid-operated, 2-way, normally closed, poppet-type, screw-in hydraulic cartridge valve, designed for low leakage blocking and load holding applications.

工作原理 OPERATION

斷電時，SV12-22 用作單向閥，允許油液從①流向②，同時截止油液從②流向①。通電后，閥芯提升，從而打開從②流向①的油液通道。此模式允許雙向流動。

When de-energized, the SV12-22 acts as a check valve, allowing flow from ① to ②, while blocking flow from ② to ①.

When energized, the poppet lifts to open the ② to ① flow path. In this mode, bidirectional flow is allowed.

特性

SPECIFICATIONS

符號 SYMBOL	
工作壓力 PRESSURE	240 bar 3500 psi
流量 FLOW	114 L/min 30 gpm
內漏 LEAKAGE	≤ 0.15 ml/min (3 drops/min) at 240 bar (3500 psi)
密封材料/溫度範圍 SEAL MATERIAL/ TEMPERATURE	丁腈橡膠 -30°C ~ +100°C BUNA-N -20°F ~ +210°F 氟橡膠 -20°C ~ +150°C VITON -4°F ~ +330°F
線圈額定負載 COIL DUTY RATING	可在85%至115%的額定電壓範圍內連續工作 CONTINUOUS FROM 85% TO 115% OF NOMINAL VOLTAGE
過濾 FILTRATION	≤ 25 MICRONS
介質 FLUID	礦物油或具有潤滑作用的合成油 MINERAL OIL OR SYNTHETIC FLUID WITH LUBRICANT PROPERTIES
粘度 VISCOSITY	10.8~420 cSt 50~2000 ssu
閥孔 CAVITY	VC12-2

性能 (只針對插件)

TYPICAL PERFORMANCE (Cartridge only)

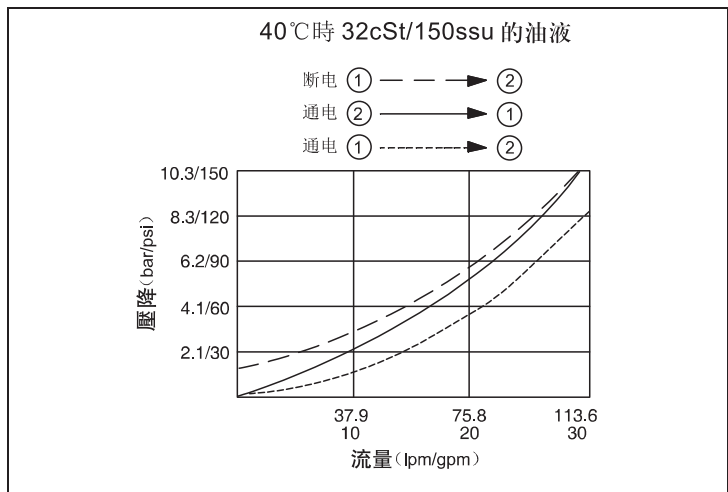

訂貨型號

HOW TO ORDER

SV12 - 22

選項 Option
 無 None
S: 150μ 過濾網
150μ Screen
M: 應急手控
Manual Override

密封材料
Seal Material
N: 丁腈橡膠 Buna-N
V: 氟橡膠 Viton

線圈終端
Coil Termination
DG: DIN43650
DL: 導線 Leadwires
DR: Deutsch DT04-2P
AG: DIN43650
AP: 1/2 英寸導線管
1/2 in. Conduit

線圈電壓
Coil Voltage
0: 無線圈
12: DC 12V
24: DC 24V
115: AC 115V
230: AC 230V

A
B
C
D
E
F
G
H
I
J
K

錐閥



兩通插裝閥閥孔 2-Way Cartridge Cavities

單位: mm

VC08-2

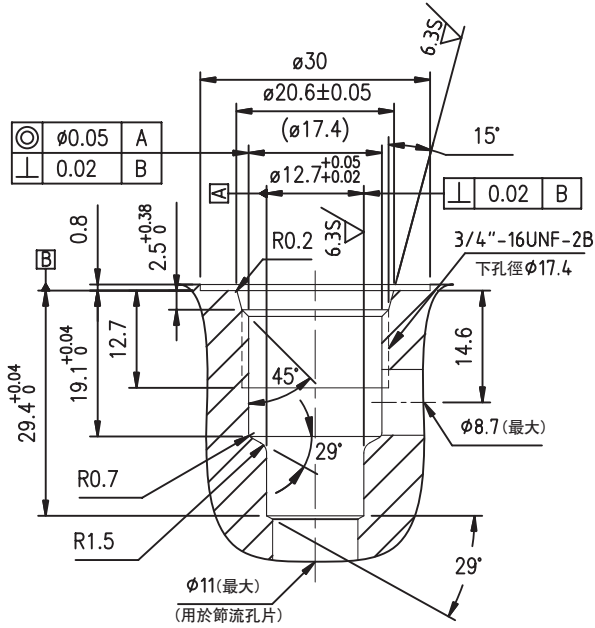

VC10-2

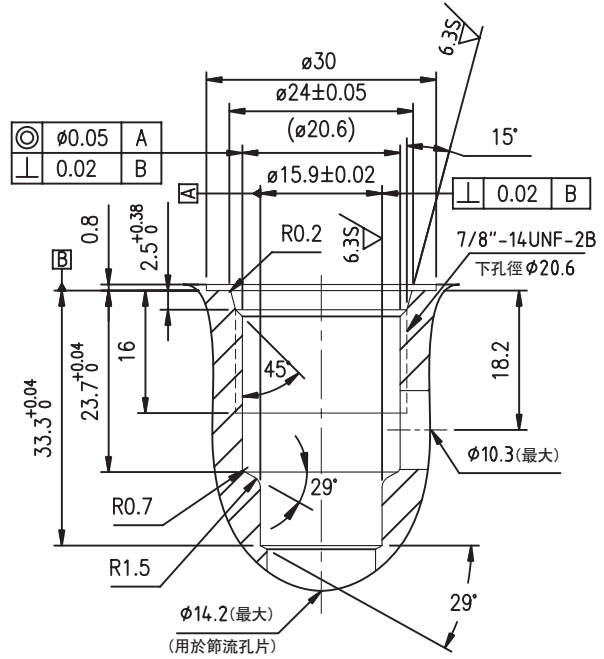

VC12-2

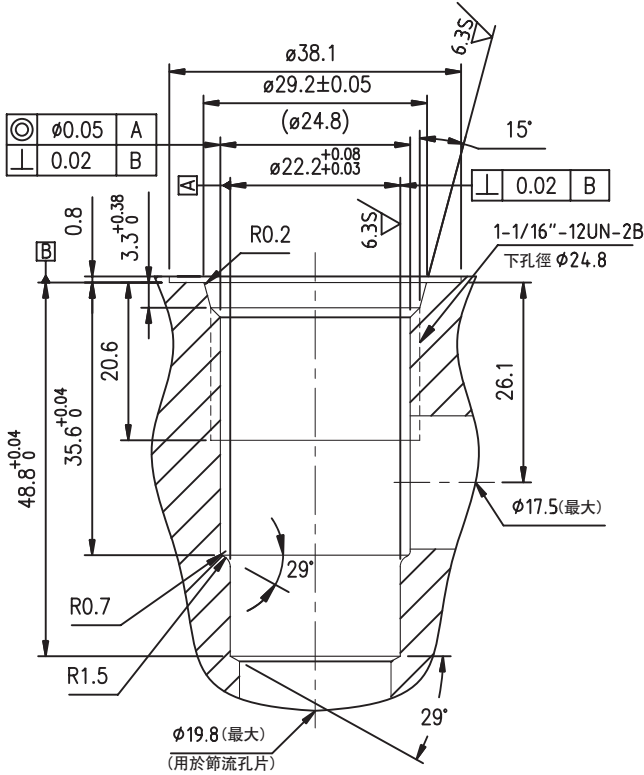

VC16-2

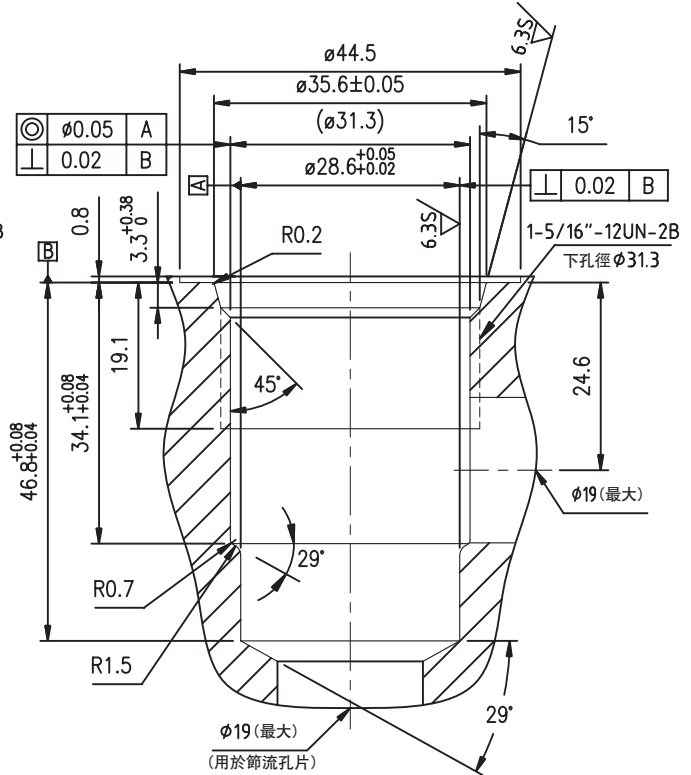

A
B
C
D
E
F
G
H
I
J
K

插裝閥閥孔